

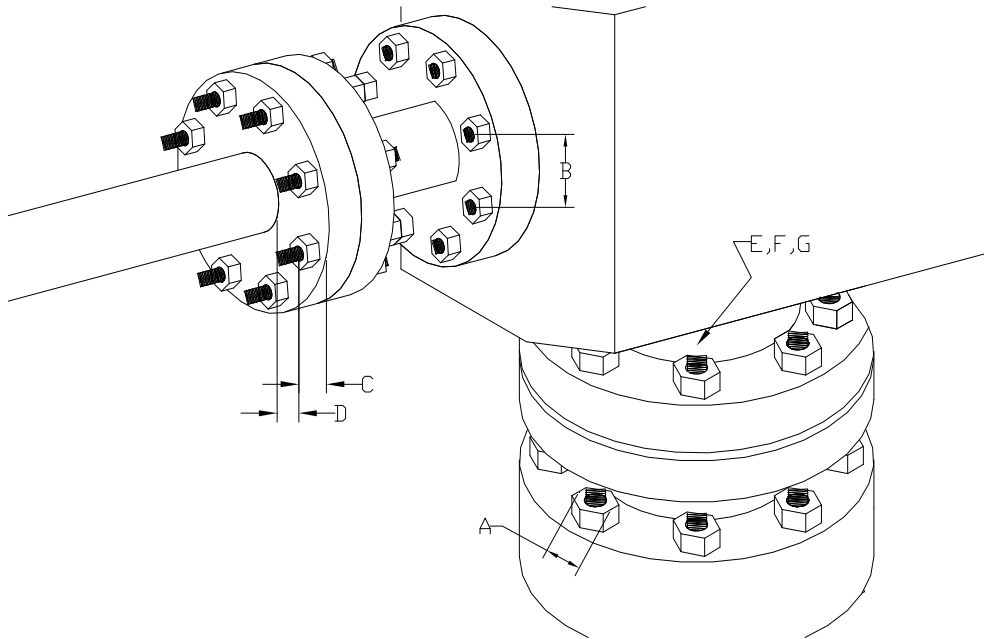

APPLICATION DATA SHEET



- | | |
|--|-------|
| A. SIZE OF NUT FROM FLAT TO FLAT | _____ |
| B. CENTER OF BOLT TO CENTER OF NEXT BOLT | _____ |
| C. CENTER OF BOLT TO EDGE OF FLANGE | _____ |
| D. CENTER OF BOLT TO INSIDE PIPE | _____ |
| E. VERTICAL CLEARANCE ABOVE STUD | _____ |
| F. DIAMETER OF STUD | _____ |
| G. LENGTH OF STUD ABOVE NUT | _____ |
| H. APPROXIMATE TORQUE/TENSION REQ'D | _____ |

WASHER, IF APPLICABLE	
	A. WASHER THICKNESS _____
	B. WASHER DIAMETER _____
	C. SPOTFACE DEPTH _____
	D. SPOTFACE DIAMETER _____